

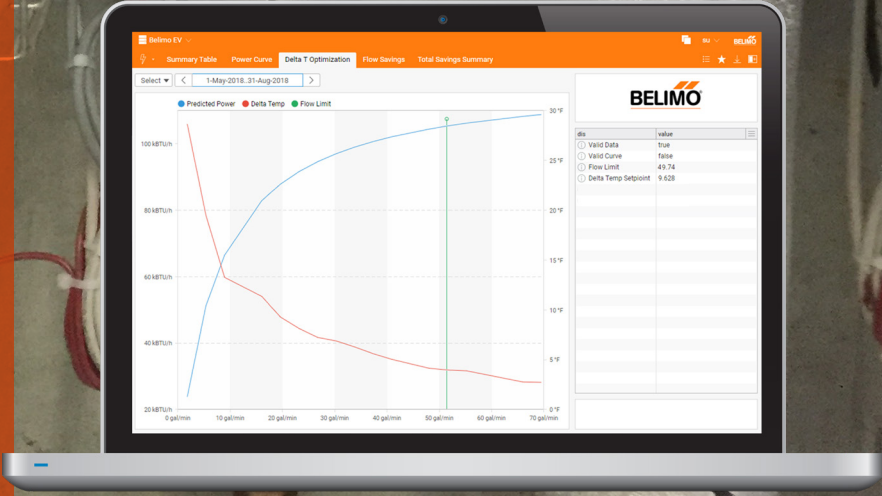

# Platform for On-Site Energy Valve Optimization



**Belimo Clear Edge**

# Table of Contents

- 2 Quick Start Guide**
- 3 Energy Valve Pod Introduction**
- 4 Energy Valve Config App**
- 10 Energy Valve App**
- 15 Historian**
- 18 Admin App (Appliance Only)**
- 18 POD Hardware**

# Quick Start Guide

Quick Start instructions are intended for users that are connecting to the Belimo Clear Edge.

## Supported Hardware

- EAP005, EAP020, EAP050

## Default IP Settings

- Port 1: (Configurable)
  - IP Address: DHCP
- Port 2: (Service Port)
  - IP Address: 100.100.1.100
  - Subnet: 255.255.255.0

## Default Credentials

- Administrator:
  - Username: admin
  - Password: Admin
- Operator:
  - Username: belimo
  - Password: Belimo

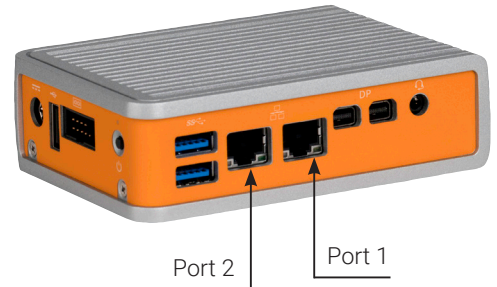

## Application Details

The default application installed will follow a consistent naming pattern for uniqueness. This naming convention is as follows: belimoEv<serialNumber>  
The UI will display as BelimoEv without the serial number.

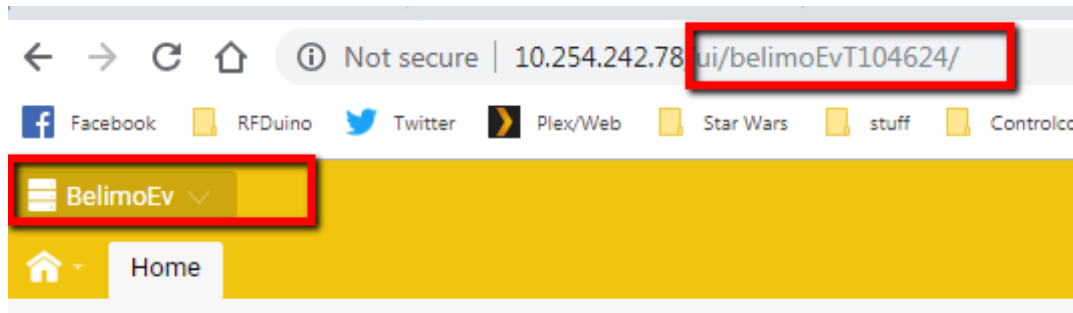

## Changing IP Settings

1. Plug a network cable from a computer to the Service Port of the device.  
Change computer network settings as appropriate to access the application in a web browser on the IP address provided above.
2. Log in using the admin user.
3. Click the BelimoEv project, then select the IP Config App.

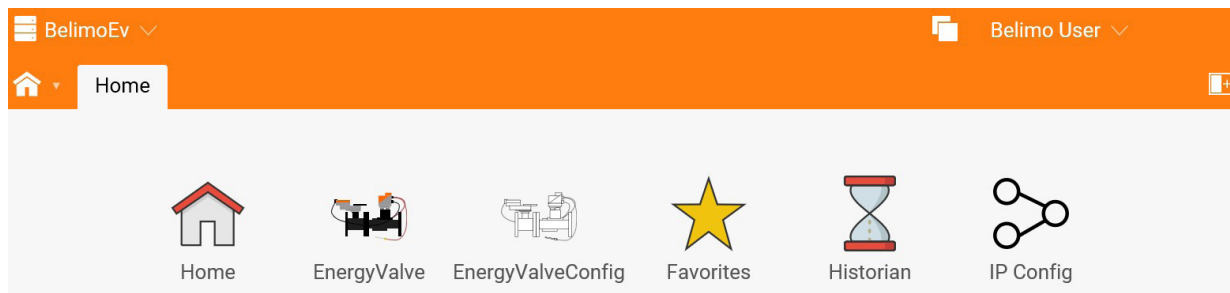

4. Change the IP settings for Port 1 as required and click submit.

Submit

DHCP True

IP Address

CIDR 24 - 255.255.255.0

Default Gateway

DNS 1

DNS 2

ipConfigTemplate ✓

5. Plug the device into the building's network on Port 1.

## Energy Valve Pod Introduction

Your Automated Energy Valve Application includes two Apps.

1. EnergyValveConfig – Provides configuration, settings for the installer or provider.
2. EnergyValve – Provides visualizations for the end-user.

Access to each App can be configured independently through the Host > User View.

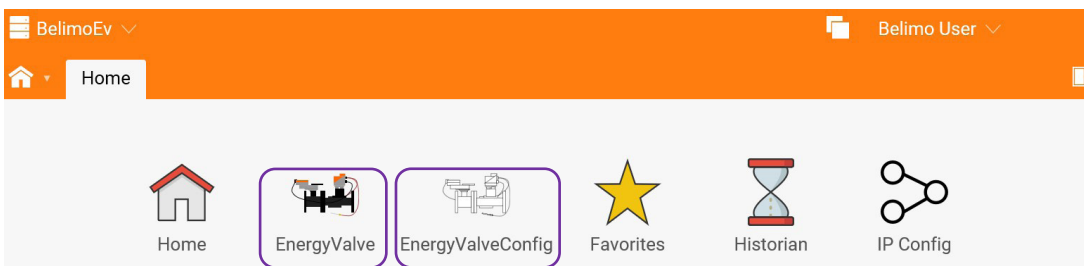

# Energy Valve Config App

There are 6 views in the Energy Valve config app.

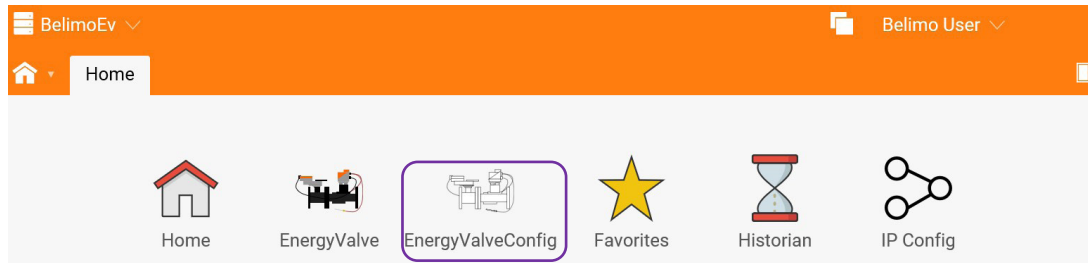

1. Connections - Add, remove and manage your Energy Valve connections and equipment
2. Setpoints - Individual and group management of setpoints
3. Settings - Application settings and assumptions
4. Log - Log of all setpoint changes
5. DT Manager Guidance - Provides guidance on how and when to use DT Manager
6. Licensing and Docs - License your installation

## Connections

Before you can add an energy valve to your installation you will need to make a BACnet connection to the valve. The Connections View has one table and several buttons along above the top row. The table will list the existing connections that have been created using one of the two ways of discovering an energy valve. There are scroll bars available at the bottom and right-hand sides of the table to view all connections and their respective tags. On the next page are the steps to import an energy valve.

id	bacnetConn	bacnetDeviceName	bacnetDeviceStatus	bacnetVersion	conn	connState	connStatus	connTuningRef	dis
EV-139 Grnd CBC Main	✓	EV-139 Grnd CBC Main	? OPERATIONAL	1.12	✓	open	✓ ok	Energy Valve Slow Poll	EV-139 Grnd CBC Main
EV-22 HRV-2 CHWV	✓	EV-22 HRV-2 CHWV	? OPERATIONAL	1.12	✓	open	✓ ok	Energy Valve Slow Poll	EV-22 HRV-2 CHWV
EV-111 VAV-11 HWV	✓	EV-111 VAV-11 HWV	? OPERATIONAL	1.12	✓	open	✓ ok	Energy Valve Slow Poll	EV-111 VAV-11 HWV
EV-120 CUH-1 hww	✓	EV-120 CUH-1 hww	? OPERATIONAL	1.12	✓	open	✓ ok	Energy Valve Slow Poll	EV-120 CUH-1 hww
EV-013 RTU-M1 HWV	✓	EV-013 RTU-M1 HWV	? OPERATIONAL	1.12	✓	open	✓ ok	Energy Valve Slow Poll	EV-013 RTU-M1 HWV
Energy Valve V-151	✓	Energy Valve V-151	? OPERATIONAL	1.12	✓			Energy Valve Slow Poll	Energy Valve V-151
EV-131 UH-5 HWV	✓	EV-131 UH-5 HWV	? OPERATIONAL	1.12	✓			Energy Valve Slow Poll	EV-131 UH-5 HWV
EV-11 RTU-W1 HWV	✓	EV-11 RTU-W1 HWV	? OPERATIONAL	1.12	✓	open	✓ ok	Energy Valve Slow Poll	EV-11 RTU-W1 HWV
RTU-M2 CHW	✓	RTU-M2 CHW	? OPERATIONAL	1.12	✓	open	✓ ok	Energy Valve Slow Poll	RTU-M2 CHW
RTU-M2 CHW	✓	RTU-M2 CHW	? OPERATIONAL	1.12	✓			Energy Valve Slow Poll	RTU-M2 CHW
EV-127 UH-1 HWV	✓	EV-127 UH-1 HWV	? OPERATIONAL	1.12	✓	open	✓ ok	Energy Valve Slow Poll	EV-127 UH-1 HWV
EV-137 Grnd HWV Main	✓	EV-137 Grnd HWV Main	? OPERATIONAL	1.12	✓	open	✓ ok	Energy Valve Slow Poll	EV-137 Grnd HWV Main
Energy Valve V-143	✓	Energy Valve V-143	? OPERATIONAL	1.12	✓			Energy Valve Slow Poll	Energy Valve V-143
EV-18 RTU-M3 CHWV	✓	EV-18 RTU-M3 CHWV	? OPERATIONAL	1.12	✓			Energy Valve Slow Poll	EV-18 RTU-M3 CHWV

### Step 1: Adding a Connection

The two ways to add new energy valve connections are as follows:

- 1. Energy Valve Discovery** – This button will prompt you for a port number for a BACnet Device Discovery. If you leave this field blank, the default port will be 47808. In order for BACnet Discovery to work the Belimo Energy Valve Pod must be installed on a device that is connected to the BACnet network. All Belimo Energy Valves that reside on the BACnet network will be automatically added to your connections. BACnet Discovery may take several minutes depending on network size and latency.
- 2. Manual Add Conn** – This button will prompt the user for the relevant network information to import a single specific valve. For BACnet/IP valves the information required is IP Address, port number, device ID. If the energy valve is on a BACnet/MSTP network then it also requires a Mac Address and Network ID. Once the information is entered, the single energy valve connection will be created.

Once the connections are added, it is highly recommended to run the Reload Table button, which will ping all connections and give a live connection status. You will see a green check mark next to an “OK” under the “conn status” if the connection was successful. If there is one connection that you’d like to ping, you can also select that device on the table and click the Ping button. That will refresh all connection status information for that device.

### Step 2: Adding the valve as a piece of equipment in the database.

Once the connection state is OK as described above, you can now move on to creating the device as a piece of equipment, as well as bind the points from the BACnet device to the points in the database. This is all done using the **Add Valve As Equip** button.

Before you take this next step check the connection “dis” tag. This will become the navigation name “navName” for the newly created equipment. If necessary, select the connection and click Edit to change the “dis” tag.

Once clicked, the user is prompted by a window with two dropdowns –

- **siteRef** – The user picks which site that each valve selected will be created under. Double click on the site and it will show up on the right hand side.
- **energyValveRef** – The user then picks one or more valves to then create under the selected site. Double click on the valve(s) and they slide to the right hand column. Then hit OK.
- **tz** – If the user has installed the pod in an existing database, the valves will automatically use the time zone of the existing database. If the user is using the Belimo Appliance the user must select a time zone for the facility in which the valves were installed.

Once started, the Add Valve As Equip function runs in the background, creating the equipment and point records, tagging them correctly, and binding them to the point on the BACnet device. Each equip selected will take around 10 seconds so if there are a lot of connectors being imported as equipment, it will take a few minutes. Once the action is completed you should be able to see the live data in the **Setpoints View**.

In the Connections View, you can also **Trash** and **Duplicate** the connections that you create. Clicking the “Trash” button will not only delete the connection, but also any equipment that was added for that connection and any associated points and histories.

## Setpoints

The Setpoints View has one table, with supplemental buttons along the top of the view. Each valve will have its own row in the table with the “dis” tag acting as the device name, as well as the imported **Device ID**, followed by each setpoint available, labeled along the top row. Those setpoints can be refreshed using the **Reload Table** button.

dis	objectID	Vmax_gpm	Override	Control Mode	DeltaT Limitation	Delta Setpoint	Setpoint Flow Delta Temp	Optimize DT Mode	Optimiz
CUH-5 EV-124	DEVICE:3025	2.0 gal/min	None	FlowCtrl	Disabled	10.0 Δ°F	0.499 gal/min	Optimize DT	Insufficient
EV-013 RTU-M1 HWV	DEVICE:3007	96.0 gal/min	None	FlowCtrl	dT-Manager	40.0 Δ°F	11.41 gal/min	Optimize DT	Insufficient
EV-11 RTU-W1 HWV	DEVICE:3005	112 gal/min	None	FlowCtrl	dT-Manager	40.0 Δ°F	11.41 gal/min	Optimize DT	Invalid Cur
EV-111 VAV-11 HWV	DEVICE:3020	4.0 gal/min	None	FlowCtrl	dT-Manager	10 Δ°F	0.499 gal/min	Optimize DT	Insufficient
EV-116 VAV-7 hww	DEVICE:3017	5.999 gal/min	None	FlowCtrl	dT-Manager	10 Δ°F	10.3 gal/min	None	Unknown
EV-118 VAV-8 hww	DEVICE:3019	8.999 gal/min	None	FlowCtrl	dT-Manager	5 °F	0.927 gal/min	Optimize DT	Insufficient
EV-120 CUH-1 hww	DEVICE:3021	2.0 gal/min	None	FlowCtrl	Disabled	10 Δ°F	0.499 gal/min	Optimize DT	Insufficient
EV-123 CUH-4 HWV	DEVICE:3024	2.0 gal/min	None	FlowCtrl	Disabled	18 Δ°F	5.548 gal/min	None	Unknown
EV-125 CUH-6 hww	DEVICE:3026	2.0 gal/min	None	FlowCtrl	Disabled	1.8 Δ°F	0.499 gal/min	Optimize DT	Insufficient
EV-126 CUH-7 HWV	DEVICE:3027	2.0 gal/min	None	FlowCtrl	Disabled	1.8 Δ°F	0.499 gal/min	Optimize DT	Insufficient
EV-127 UH-1 HWV	DEVICE:3028	3.0 gal/min	None	FlowCtrl	Disabled	18 Δ°F	5.548 gal/min	None	Unknown
EV-128 UH-2 HWV	DEVICE:3029	3.001 gal/min	None	FlowCtrl	Disabled	18 Δ°F	5.548 gal/min	None	Unknown
EV-129 UH-3 HWV	DEVICE:3030	3.0 gal/min	None	FlowCtrl	Disabled	18 Δ°F	5.548 gal/min	None	Unknown
EV-130 UH-4 HWV	DEVICE:3031	3.0 gal/min	None	FlowCtrl	Disabled	18 Δ°F	5.548 gal/min	None	Unknown

Along with viewing the setpoint data, the Setpoints View allows the user to change one or multiple setpoints at one time. By selecting the **Energy Valve Config** button, the user is prompted by a pop-up setpoint configuration wizard. The top dropdown is an energy valve picker. You can select one or more valves to configure. By default, all setpoints are unselected, so in order to change a setpoint, you must first select the valve(s), and then select the check box on the left-hand side of the pop-up window. This will allow the user to edit the text field or select the appropriate drop down. Once the valve is configured, click the OK button at the bottom. **This will write back the setpoints to the BACnet device.**

## Automated DT Optimization

This is also where the user will turn on the automated DT Optimization. To choose this option, select a valve and change optimizedDT from “None” to “Optimize DT” or “Optimize DT – Scaling”. When you hit submit, the system will attempt to create a valid curve required to establish the Delta T Setpoints. If enough data is not available, a message of “Insufficient Data” or “Invalid Curve Fit” will display in the “Optimization Validation” column. Each evening, the system will use the additional data to attempt to set the setpoint. Once a valid curve is identified, the system will automatically set the Delta T Limitation and Delta T setpoints.

## Settings

The Settings View has three main parts.

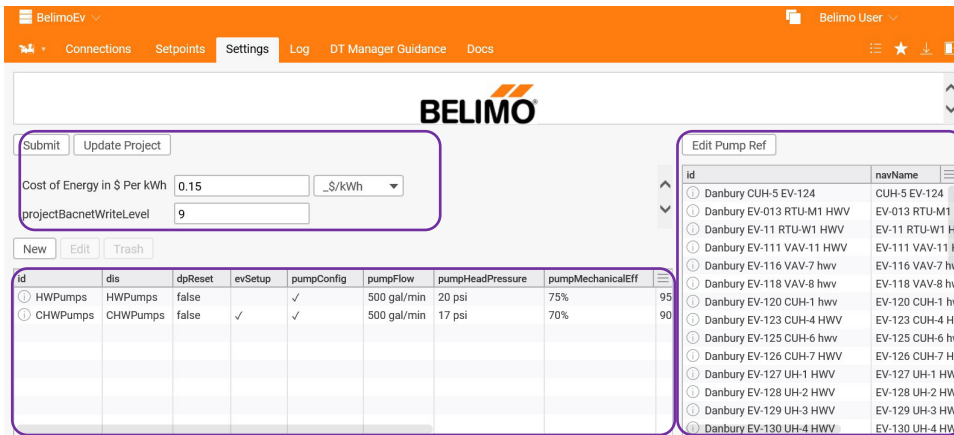

1. System Settings on the top left. This is where the user enters the cost of energy as well as the bacnetWriteLevel. If the bacnetWriteLevel is changed. The user can make changes to either of these setting and hit **Submit**. If changing the bacnetWriteLevel, the user must also click **Update Project** to force the changes to take effect on all existing equipment.
2. The pump editor table in the bottom left. You can create, edit, duplicate, and delete pumps that will get assigned to each energy valve. Pump 1 is created by default and all energy valves are initially bound to it, but by selecting that pump and clicking the edit button, the user can configure the pump variables including **Pump Head Pressure, Pump Mechanical Efficiency, Pump Motor Efficiency, Pump Flow, DP Reset, and Pump Power**. Pump Power is disabled by default. To adjust Pump Power, click the check box and edit the text field. These inputs are used to calculate the energy savings associated with reduced flow.
3. The pump configuration table on the right side of the screen shows which pumps are assigned to which energy valves. All energy valves are shown and by selecting the **Edit Pump Ref** button you can select one or more pumps and assign them a pump created in the Pump Editor.

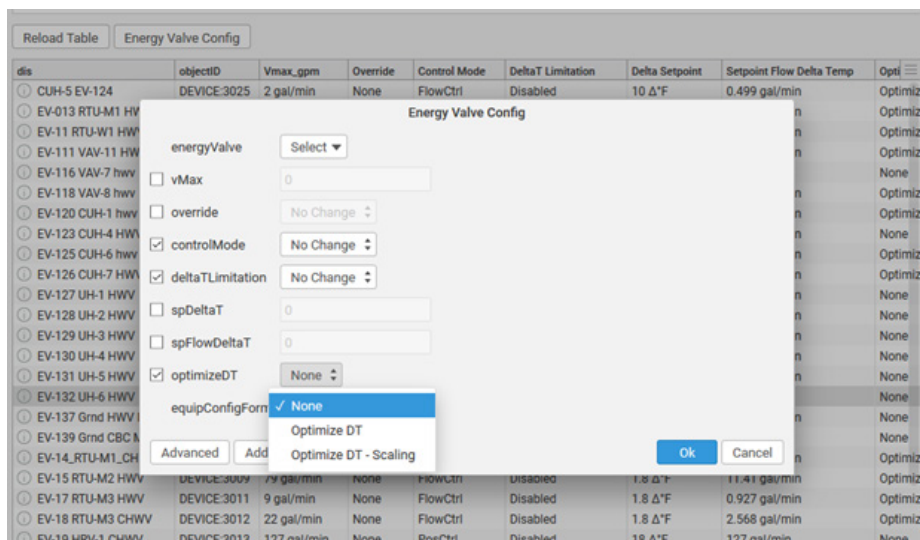



## Log

The Log View shows all BACnet setpoints that have been changed from inside the Setpoints View outlined above. It shows which point was edited, the BACnet write value, the BACnet write level, and which user edited the setpoint.

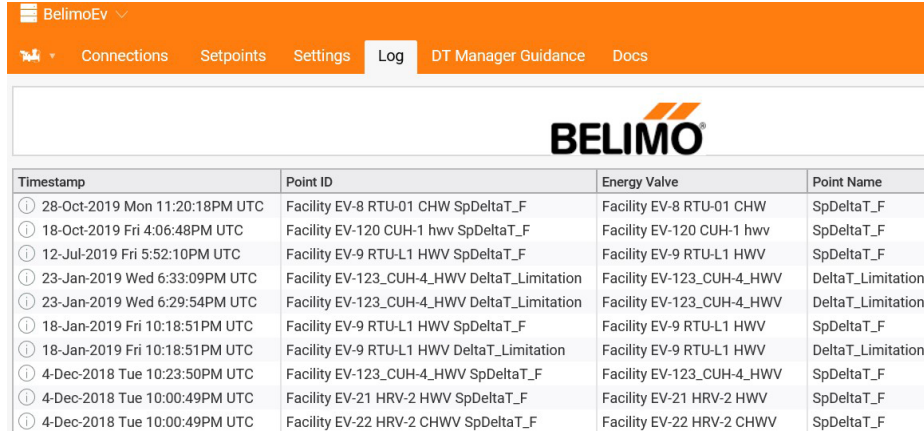

The screenshot shows the BelimoEv interface with the 'Log' tab selected. The table below lists the following data:

Timestamp	Point ID	Energy Valve	Point Name
28-Oct-2019 Mon 11:20:18PM UTC	Facility EV-8 RTU-01 CHW SpDeltaT_F	Facility EV-8 RTU-01 CHW	SpDeltaT_F
18-Oct-2019 Fri 4:06:48PM UTC	Facility EV-120 CUH-1 hww SpDeltaT_F	Facility EV-120 CUH-1 hww	SpDeltaT_F
12-Jul-2019 Fri 5:52:10PM UTC	Facility EV-9 RTU-L1 HWV SpDeltaT_F	Facility EV-9 RTU-L1 HWV	SpDeltaT_F
23-Jan-2019 Wed 6:33:09PM UTC	Facility EV-123_CUH-4_HWV DeltaT_Limitation	Facility EV-123_CUH-4_HWV	DeltaT_Limitation
23-Jan-2019 Wed 6:29:54PM UTC	Facility EV-123_CUH-4_HWV DeltaT_Limitation	Facility EV-123_CUH-4_HWV	DeltaT_Limitation
18-Jan-2019 Fri 10:18:51PM UTC	Facility EV-9 RTU-L1 HWV SpDeltaT_F	Facility EV-9 RTU-L1 HWV	SpDeltaT_F
18-Jan-2019 Fri 10:18:51PM UTC	Facility EV-9 RTU-L1 HWV DeltaT_Limitation	Facility EV-9 RTU-L1 HWV	DeltaT_Limitation
4-Dec-2018 Tue 10:23:50PM UTC	Facility EV-123_CUH-4_HWV SpDeltaT_F	Facility EV-123_CUH-4_HWV	SpDeltaT_F
4-Dec-2018 Tue 10:00:49PM UTC	Facility EV-21 HRV-2 HWV SpDeltaT_F	Facility EV-21 HRV-2 HWV	SpDeltaT_F
4-Dec-2018 Tue 10:00:49PM UTC	Facility EV-22 HRV-2 CHWV SpDeltaT_F	Facility EV-22 HRV-2 CHWV	SpDeltaT_F

## DT Manager Guidance

This view provides documentation for when to use DT Manager vs. DT Manager – Scaling.

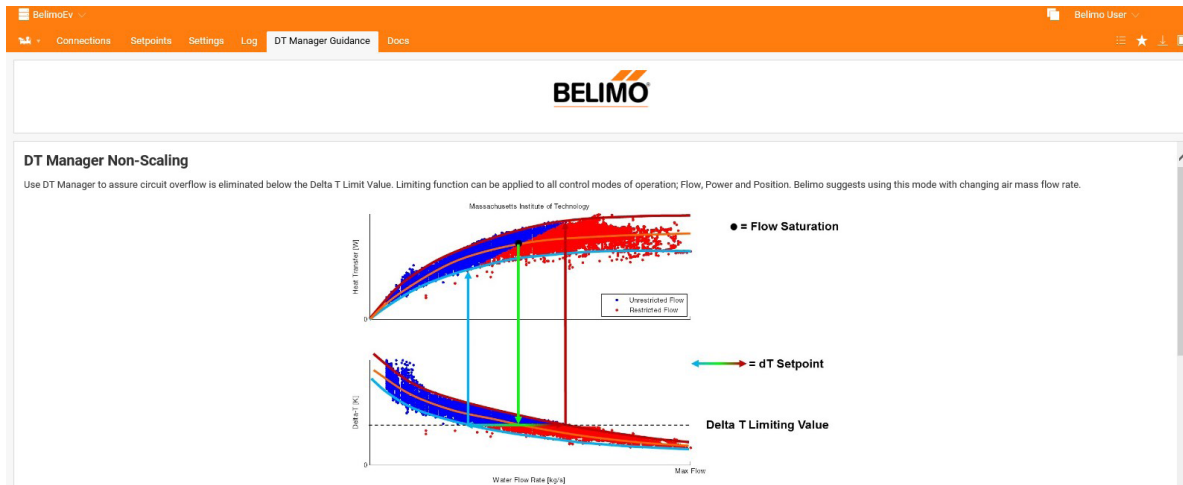

## DT Manager Scaling

This limiting function can be applied to the Flow and Power modes of operation. Building operators are assured circuit overflow is eliminated below the scaled (variable) dT setpoint. Belimo suggests using this mode with changing temperature of the inlet air flow or inlet water supply.

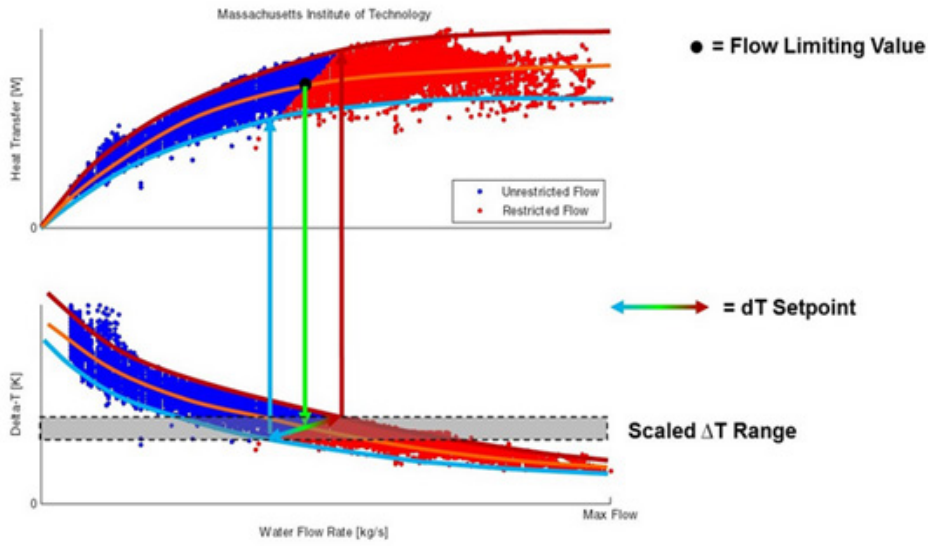

# Energy Valve App

There are 5 views in the Energy Valve app.

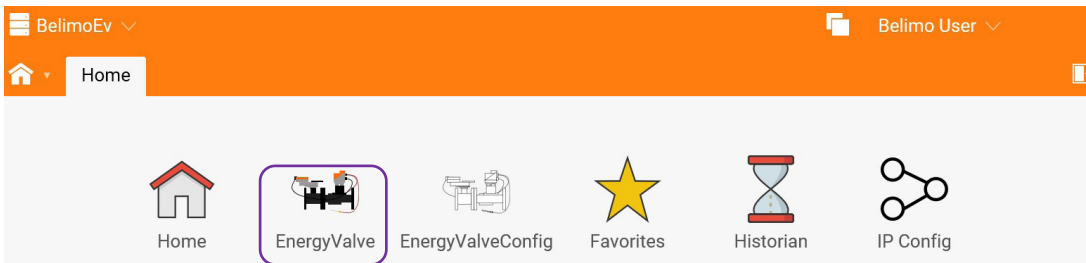

1. Summary Table - Snapshot of key performance indicators from all valves
2. Power Curve - View power and DT curve for a select valve
3. Delta T Optimization - Manually identify the optimum DT setpoint for a select valve
4. Flow Savings - Estimate flow savings from a valve in DT Manager mode
5. Total Savings Summary - Estimates total pump and site energy savings

## Summary Table

The Summary Table View consists of one main table showing all non-setpoints for each imported energy valve. This table will show current values upon page refresh. The **Reload Table** button will refresh all current values.

Valve Name	Bacnet Object ID	Temp #1	Temp #2	Delta Temp	Delta Setpoint	Current Flow	Current Power	Last 30 Days Flow	Last 30 Days Energy Use	Last 30 Days kBTU/gal
① CUH-5 EV-124	DEVICE:3025	74.44 °F	76.04 °F	1.598 Δ°F	10.0 Δ°F	0 gal/min	0.003 kBTU/h	1,355 gal	306 kBTU	0.226 kBTU/gal
① EV-013 RTU-M1 HWV	DEVICE:3007	78.43 °F	74.51 °F	3.921 Δ°F	40 Δ°F	0 gal/min	0.003 kBTU/h	75,584 gal	40,962 kBTU	0.542 kBTU/gal
① EV-11 RTU-W1 HWV	DEVICE:3005	78.97 °F	70.45 °F	8.519 Δ°F	40.0 Δ°F	0 gal/min	0.003 kBTU/h	111,854 gal	48,827 kBTU	0.437 kBTU/gal
① EV-111 VAV-11 HWV	DEVICE:3020	72.38 °F	74.93 °F	2.554 Δ°F	10 Δ°F	0 gal/min	0.003 kBTU/h	0.262 gal	2.535 kBTU	9.692 kBTU/gal
① EV-116 VAV-7 hww	DEVICE:3017	132 °F	79.2 °F	52.56 Δ°F	10 Δ°F	0.15 gal/min	3.94 kBTU/h	11,456 gal	4,394 kBTU	0.384 kBTU/gal
① EV-118 VAV-8 hww	DEVICE:3019	73.17 °F	74.54 °F	1.371 Δ°F	5 °F	0 gal/min	0.003 kBTU/h	1,474 gal	740 kBTU	0.502 kBTU/gal
① EV-120 CUH-1 hww	DEVICE:3021	83.86 °F	85.54 °F	1.677 Δ°F	10 Δ°F	0 gal/min	0.003 kBTU/h	0.774 gal	2.542 kBTU	3.284 kBTU/gal
① EV-123 CUH-4 HWV	DEVICE:3024	91.82 °F	99.19 °F	7.368 Δ°F	18 Δ°F	0 gal/min	0.003 kBTU/h	64,755 gal	18,449 kBTU	0.285 kBTU/gal
① EV-125 CUH-6 hww	DEVICE:3026	157 °F	157 °F	0.342 Δ°F	1.8 Δ°F	5.421 gal/min	0.882 kBTU/h	231,461 gal	10,474 kBTU	0.045 kBTU/gal
① EV-126 CUH-7 HWV	DEVICE:3027	157 °F	154 °F	2.486 Δ°F	1.8 Δ°F	1.727 gal/min	2.064 kBTU/h	80,111 gal	1,183 kBTU	0.015 kBTU/gal
① EV-127 UH-1 HWV	DEVICE:3028	76.22 °F	77.99 °F	1.774 Δ°F	18 Δ°F	0 gal/min	0.003 kBTU/h	16,685 gal	1,253 kBTU	0.075 kBTU/gal
① EV-128 UH-2 HWV	DEVICE:3029	77.51 °F	76.07 °F	1.44 Δ°F	18 Δ°F	0 gal/min	0.003 kBTU/h	27,809 gal	2,167 kBTU	0.078 kBTU/gal

### Power Curve

The Power Curve View has one main scatter plot chart, with two variable pickers at the top of the view. The picker on the left chooses an energy valve that has been created using the Connectors View. The picker on the right chooses a timeframe that will be used to generate the chart. Once both variables have been selected, the chart will be generated with the valve flow as the X-Axis, the valve power as the left Y-Axis and the valve Delta Temp as the right Y-Axis. This shows the relationship of power versus delta temp, based on the flow of the valve.

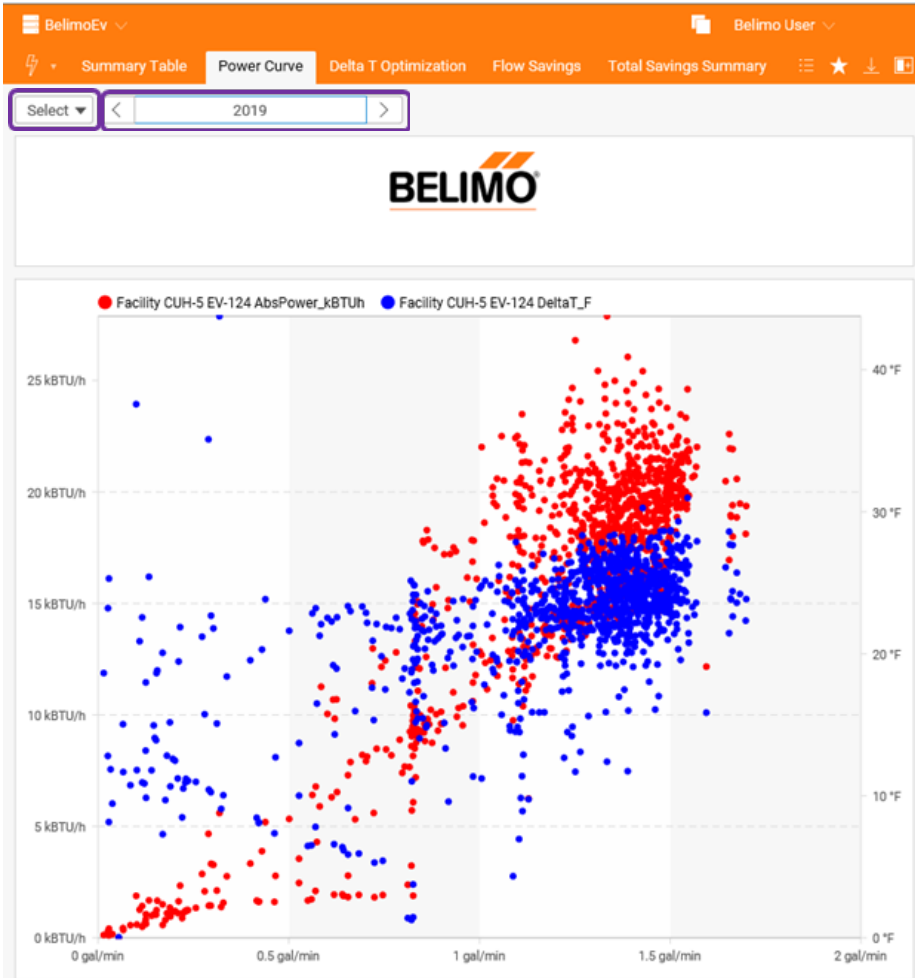

### Manual DT Optimization

The Manual DT Optimization view has two components based on the two variable pickers at the top left of the view. The left picker chooses an energy valve, and the right picker chooses a timespan that will be used to generate the curve and tables.

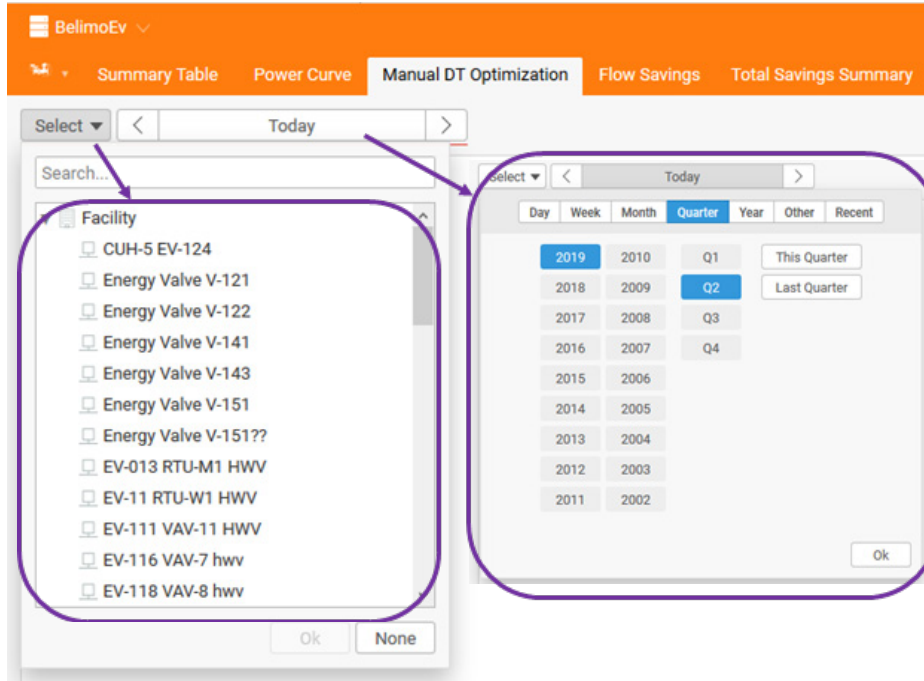

Once both variables are selected, the main line chart will consist of a predicted power curve in kBTU/h, a delta temp in Degrees Fahrenheit and a vertical flow limit in gallons per minute.

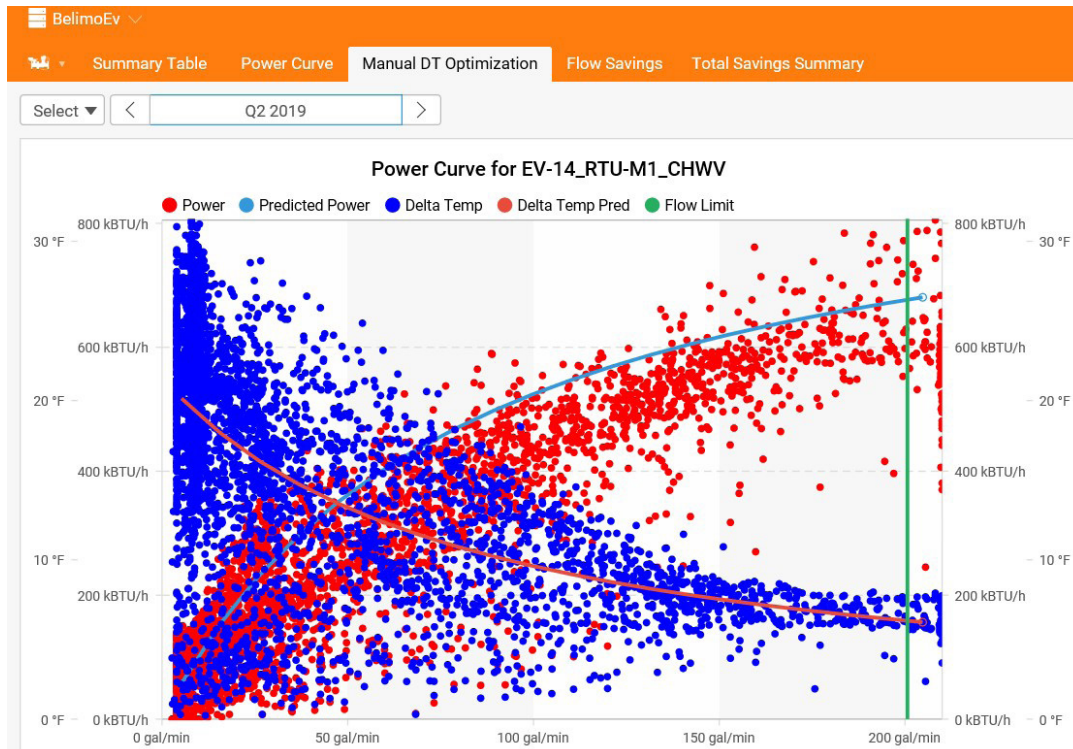

Along with the visual curves, a table on the top right will show the curve validity and statistics. The validity is checked by the MRE as well as the R-Squared value of the power curve. The statistics that go along with it are the optimal flow limit and delta temperature setpoint.

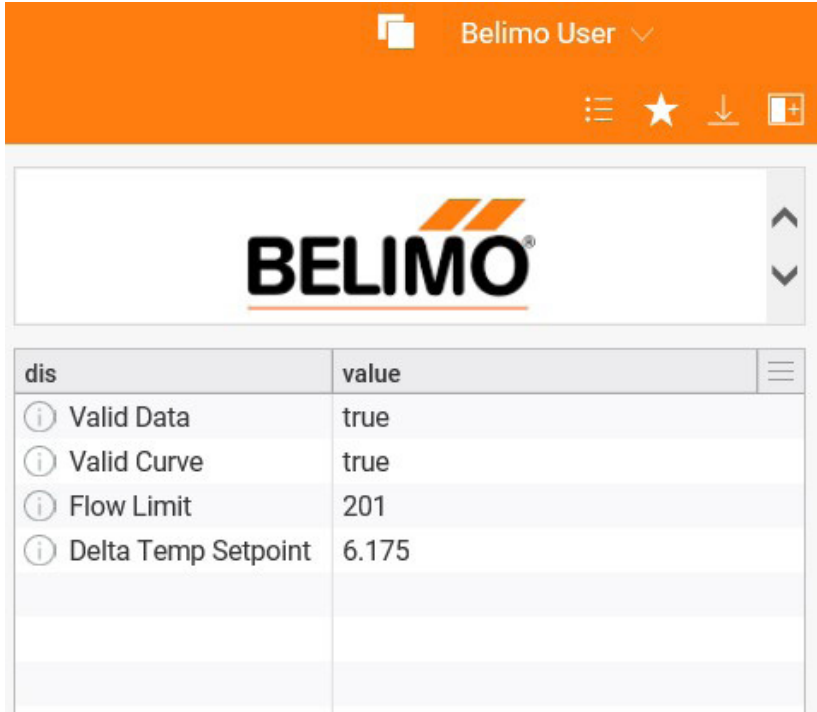

dis	value
Valid Data	true
Valid Curve	true
Flow Limit	201
Delta Temp Setpoint	6.175

### Flow Savings

The Flow Savings view has 5 variable pickers across the top of the page.

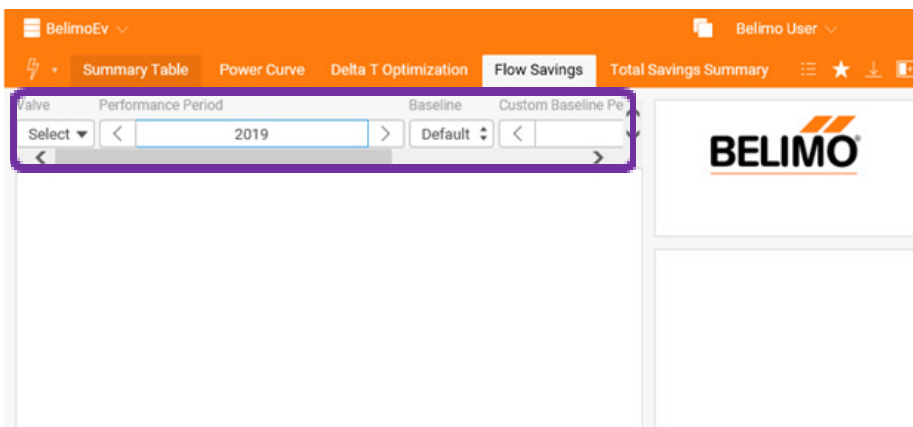

1. **Valve** – Select the valve to compare.
2. **Performance Period** – Select the period of time in which flow savings has occurred.
3. **Baseline (Default or Custom)** – Select Default to use the default baseline period if one exists. Select Custom to use a custom baseline period.
4. **Custom Baseline Period** – Enter the baseline period. If using a default baseline, select any time range.
5. **Save As Default Baseline** – Set this to True to save a custom baseline as the default for this valve.

Once all variables are selected, the chart on the left side of the screen will display the water flow rate through the valve during both the performance and baseline periods. For the performance period, the data is filtered to only show flow when DT Manager status is active. For the baseline period, the data is filtered to only show flow when the DT is less than the DT setpoint.

Finally, statistics for the valve will be displayed on the right site of the screen, including number of days DT Manager mode was enabled and total flow savings.

### Total Savings Summary

The Total Savings Summary is similar to the Flow Savings view, but provides the total flow and energy savings for all valves. Energy savings is calculated on a pump by pump basis. The user must select the Performance Period, Baseline, and Custom Baseline Period.

Site	Valve	DT Manager Enabled (duration)	Flow Reduction	Default Valve Baseline
Facility	CUH-5 EV-124	Unknown	Unknown	2019-01-01,2019-02-01
Facility	EV-013 RTU-M1 HWV	Unknown	Unknown	2019-01-22
Facility	EV-11 RTU-W1 HWV	Unknown	Unknown	2019-01-19
Facility	EV-111 VAV-11 HWV	Unknown	Unknown	2019-01-19
Facility	EV-118 VAV-8 hww	Unknown	Unknown	2019-01-19
Facility	EV-120 CUH-1 hww	Unknown	Unknown	2019-01-19
Facility	EV-123_CUH-4_HWV	Unknown	Unknown	2019-01-19
Facility	EV-125 CUH-6 hww	Unknown	Unknown	2019-01-19
Facility	EV-126 CUH-7 HWV	Unknown	Unknown	2019-01-19
Facility	EV-14_RTU-M1_CHWV	Unknown	Unknown	2019-01-19
Facility	EV-15 RTU-M2 HWV	Unknown	Unknown	2019-01-19
Facility	EV-17 RTU-M3 HWV	Unknown	Unknown	2019-01-19
Facility	EV-18 RTU-M3 CHWV	Unknown	Unknown	2019-01-19
Facility	EV-21 HRV-2 HWV	Unknown	Unknown	2019-01-19
Facility	EV-22 HRV-2 CHWV	Unknown	Unknown	2019-01-19
Facility	EV-7_RTU-01_HWV	Unknown	Unknown	2019-01-19
Facility	EV-8_RTU-01_CHW	Unknown	Unknown	2019-01-19

**Total Savings Summary**  
 DT Total Flow Savings: 0 gallons  
 Total Cost Savings: \$0  
 Total Energy Savings: 0kWh

**val**  
 No Pump Savings Available, Check Historical Data

The view consists of three tiles. The upper left tile displays a table of each energy valve, the duration that the DT Manager was enabled, the flow reduction and default valve baseline period.

The bottom left tile includes a table of each pump with the energy and cost savings.

The right tile provides the total flow, cost and energy savings for the facility.

# Historian

There are 3 views in the Historian App.

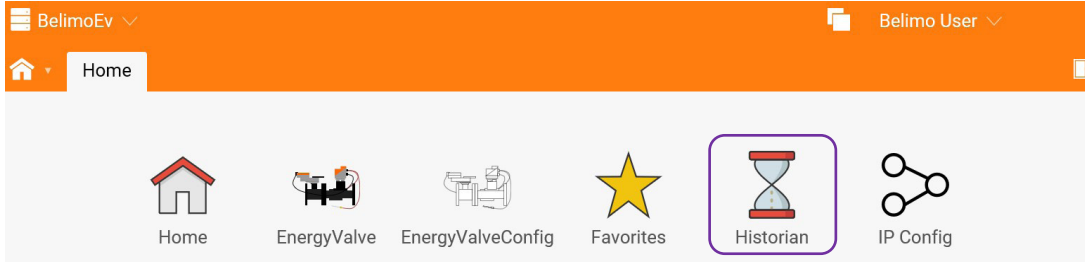

## Chart

Use the "+" button to chart data from one or more devices, including weather.

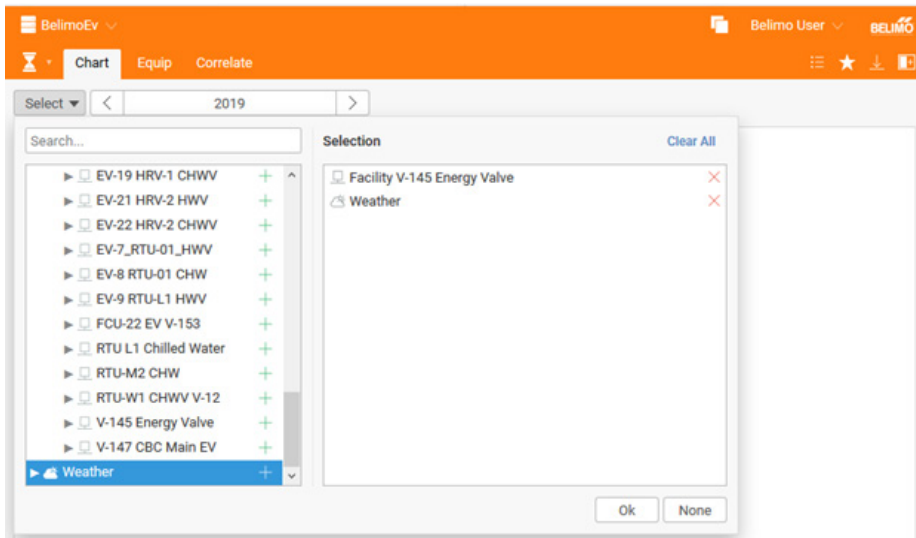



View plots with selected object name.

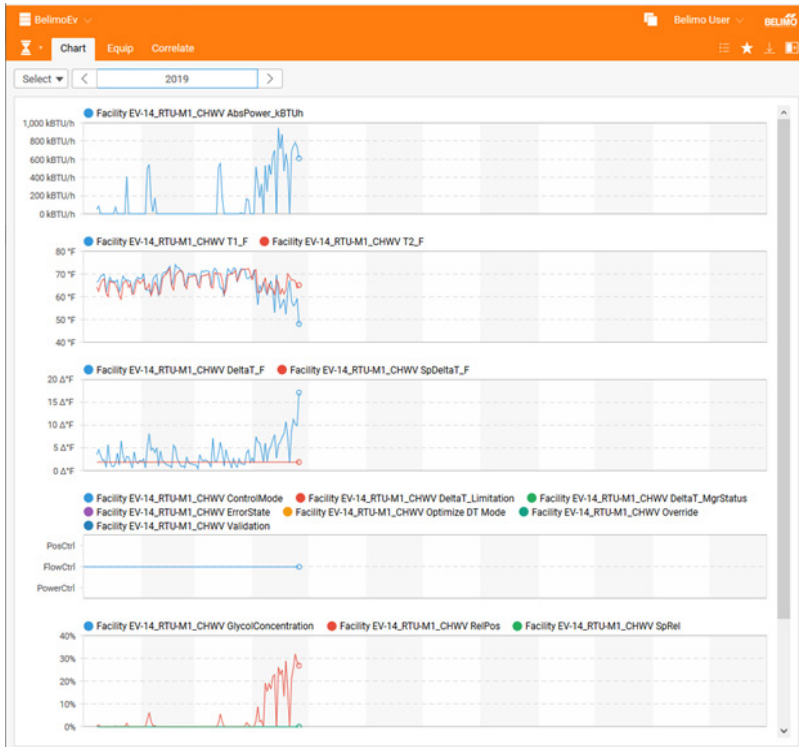

## Equipment

View plots from a single device with simple color code identification.

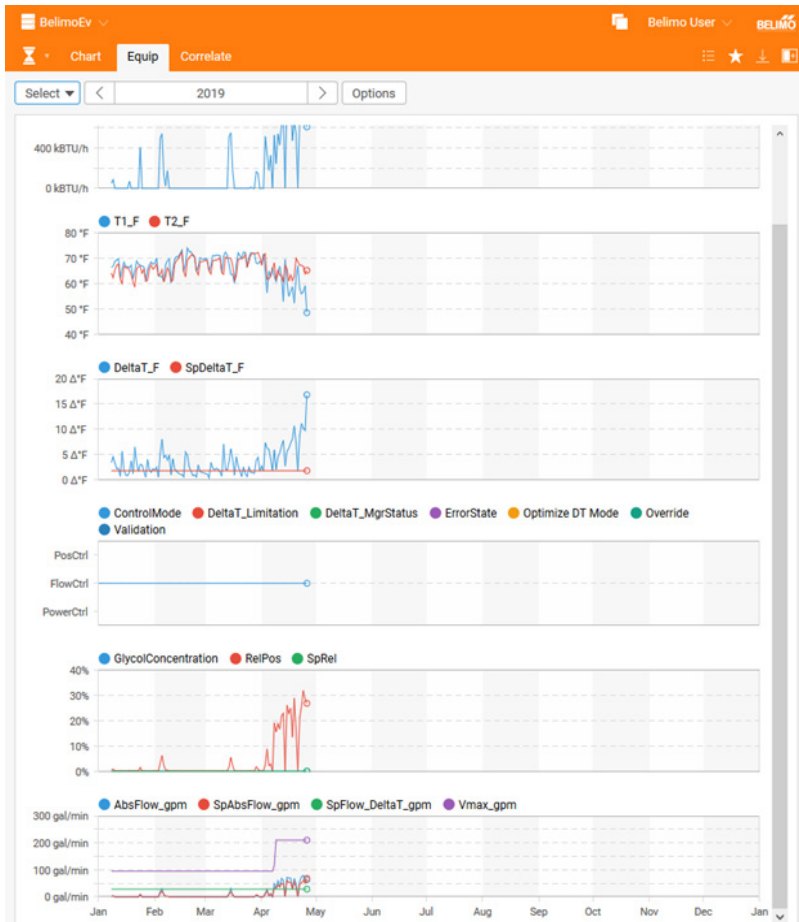

### Correlate

Select device X and Y axis parameters for custom plots.

BelimoEv Belimo User BELIMO

Chart Equip **Correlate**

X-Axis Y-Axis Filter

Select Select < 2019 > Filter

Search...

- EV-14\_RTU-M1\_CHWV
  - AbsFlow\_gpm
  - AbsPower\_kBTUh
  - ControlMode
  - DeltaT\_F
  - DeltaT\_Limitation
  - DeltaT\_MgrStatus
  - ErrorState
  - GlycolConcentration
  - Optimize DT Mode
  - Override
  - RelPos
  - SpAbsFlow\_gpm

Ok None

Example plot of flow vs. power.

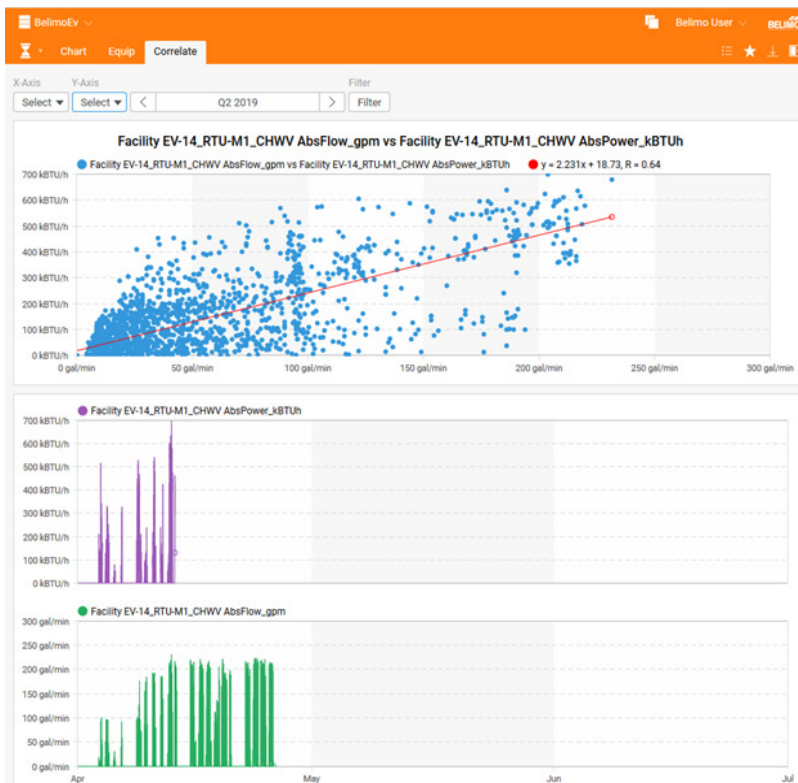

# Admin App (Appliance Only)

The Admin App can be accessed by logging in using the Admin user profile (see Quick Start Guide). Through the Admin app you can update the software.

## Update Pod

To update a software Pod follow these easy steps:

1. Click the "Choose File" button to select the pod file from your local computer.
2. Click the "Upload!"
3. Once upload is complete, click the "Restart" button. The restart process takes about 30 seconds.

# Hardware

## Regulatory Compliance and Safety Information

The following details provides international regulatory and safety compliance information for the Belimo fanless computer EAP. series.

## Declaration of Conformity

### FCC

This device complies with part 15 of the FCC rules as a Class A device. Operation is subject to the following two conditions: (1) this device may not cause harmful interference and (2) this device must accept any interference received, including interference that might cause undesired operation.

### Industry Canada Compliance Statement

This Class A digital apparatus complies with Canadian ICES-003.

### Avis de Conformité à la Réglementation d'Industrie Canada

Cet appareil numérique de la classe A est conforme à la norme NMB-003 du Canada.

### CE

This equipment complies with all application European Union (CE) directives if it has a CE marking. For this device to remain CE compliant, only CE compliant parts can be installed and proper cables and cabling techniques are required.

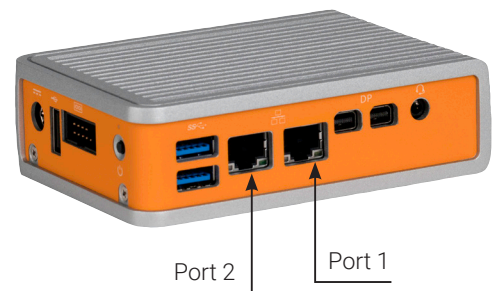

**Safe use and installation instructions**

1. Do not open or modify the device. The device uses components that comply with FCC and CE regulations. Modification of the device will void these certifications.
2. Install the device securely. Be careful handling the device to prevent injury and do not drop.
3. Wall or ceiling mounting device requires use of a mounting plate or bracket. Plate or bracket must be of metal construction and have a minimum thickness of 1mm.
4. Use M3x0.5 mm Flat Head screws to attach mounting plate or mounting brackets to threaded holes on bottom of chassis. Screws should be minimum length of 4mm. Add 1mm of screw length for every mm of additional thickness of plate or bracket beyond 1.5 mm.
5. Operational temperature must be between 0...50°C with a non-condensing relative humidity of 10...90%. Derated operational temperature of 0...40°C dependent on included power adapter. Reference below table.
6. The device can be stored at temperatures between 0...60°C.
7. Keep the device away from liquids and flammable materials.
8. Do not clean the device with liquids. The chassis can be cleaned with a cloth.
9. Allow at least 2 inches of space around all sides of the device for proper cooling. If device is mounted to vertical surface, then recommended device orientation is so that heatsink fins allow air to rise unobstructed. Alternative orientations may result in reduced operational temperature range.
10. This device is intended for indoor operation only.
11. Use UL Listed external power supply with rated output DC 12 V, 3A min.
12. Install the device only with shielded network cables.
13. Service and repair of the device must be done by qualified service personnel. This includes but is not limited to replacement of CMOS battery. Replacement CMOS battery must be of same type as original.
14. Proper disposal of CMOS battery must comply with local governance.

**WARNING:** There is danger of explosion if the CMOS battery is replaced incorrectly. Disposal of battery into fire or a hot oven, or mechanically crushing or cutting of a battery can result in an explosion.

**Exterior View**

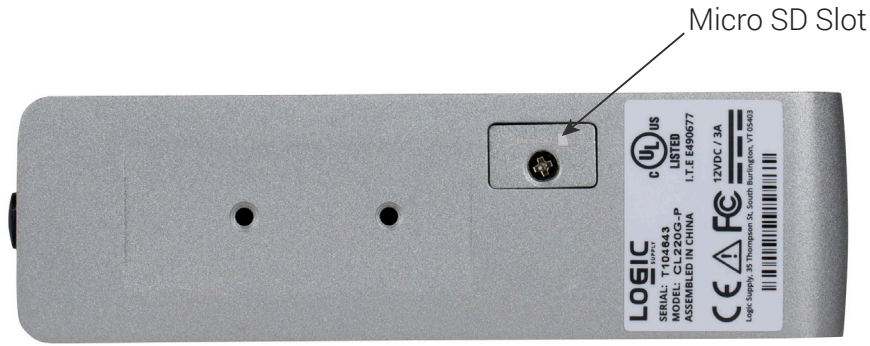

**Rear View**

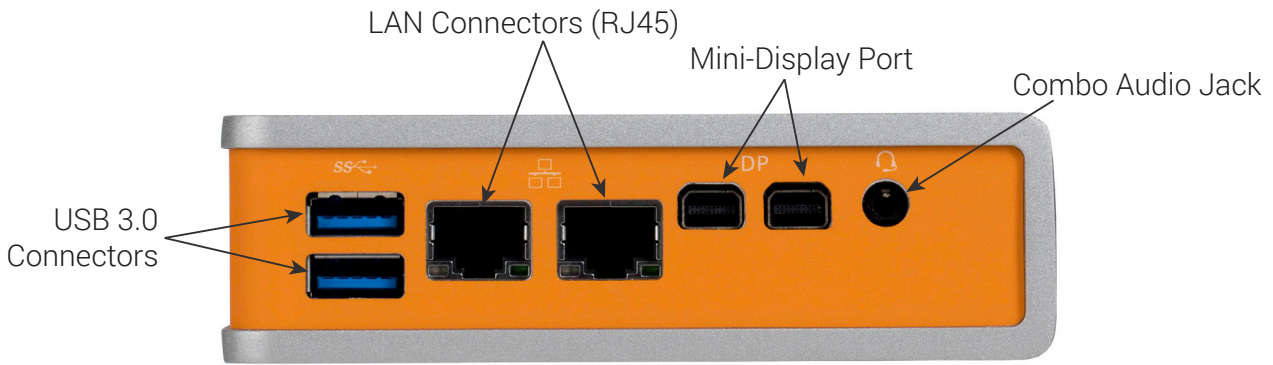

**Front View**

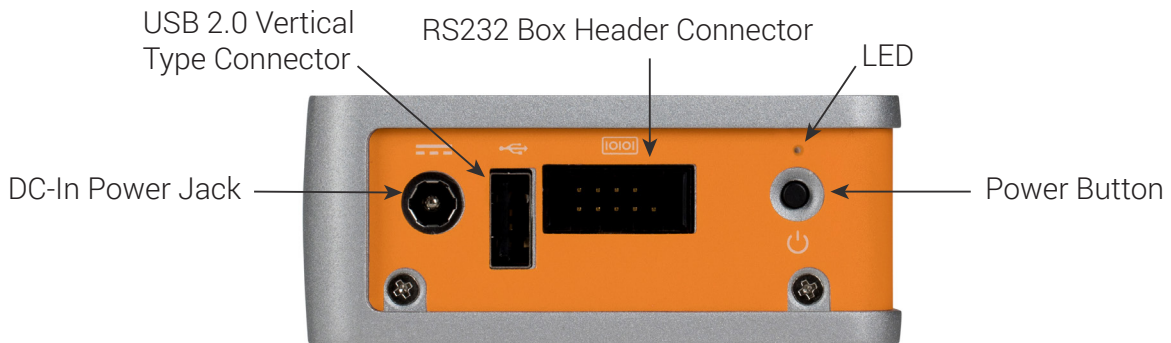

**Side View**

**System Specifications Table**

	Belimo EAP... Series
Form Factor	Pico ITX (100mm x 72mm)
Processor	Intel® Celeron®
System memory	LPDDR4 onboard DRAM
Processor Graphics	Intel® HD Graphics 500
Audio	Realtek ALC233
Super I/O	Nuvoton NCT 5524
LAN	LAN1: Realtek RTL8111H
	LAN2: Realtek RTL8111H
Expansion	Full-length mPCIe slot (PCIe/USB/mSATA signal)
	Half-length mPCIe slot (PCIe/USB signal)
WiFi Antenna	4 x Antenna holes
Onboard storage	eMMC
Rear I/O	Micro SD slot
Front I/O	mini-Display Port
	Gb LAN port
	USB3.0
Bottom I/O	1 x Power button
	1 x LED (on the backside of PCB)
	1 x USB2.0 vertical type
	1 x 12V DC-in barrel
	RS 232 Box Header Connector
Onboard Headers & Connectors	1 x RTC battery header
	1 x CEC header (module population is optional)
	1 x Clear CMOS, AT/ATX Jumper

**Belimo Americas**

USA, Latin America, and the Caribbean: [www.belimo.us](http://www.belimo.us)

Canada: [www.belimo.ca](http://www.belimo.ca), Brazil: [www.belimo.com.br](http://www.belimo.com.br)

Belimo Worldwide: [www.belimo.com](http://www.belimo.com)

